

60 AMP PRESS FIT HIGH VOLTAGE DIODES

FEATURES

- VOID FREE VACUUM DIE SOLDERING FOR MAXIMUM MECHANICAL STRENGTH AND HEAT DISSIPATION
 (Solder Voids: Typical $\leq 2\%$, Max. $\leq 5\%$ of Die Area)
- PRESS FIT INTO HEAT SINK TO FURTHER ENHANCE HEAT HANDLING CAPABILITY
- PROPRIETARY HIGH TEMPERATURE JUNCTION PASSIVATION FOR SUPERIOR RELIABILITY AND PERFORMANCE
- LOW THERMAL STRESS STRUCTURE - PASS 5 CYCLE (-55°C TO $+150^{\circ}\text{C}$) THERMAL SHOCK TEST

MECHANICAL DATA

- Case: Nickel plated copper
- Finish: All external surfaces are corrosion resistant and the contact areas are readily weldable or solderable
- Maximum Soldering Temperature: 250°C , 0.25" from case for 10 Seconds
- Mounting Position: Any. Maximum force used for diode insertion to be 12 KN
- Polarity: Color coded epoxy ring- ANODE on LEAD (Beige Ring); Part No.=B6002PFA/B6004PFA. CATHODE on LEAD (Black Ring) Part No.=B6002PFC/B6004PFC. Part No. marked on cap base.

MECHANICAL SPECIFICATION

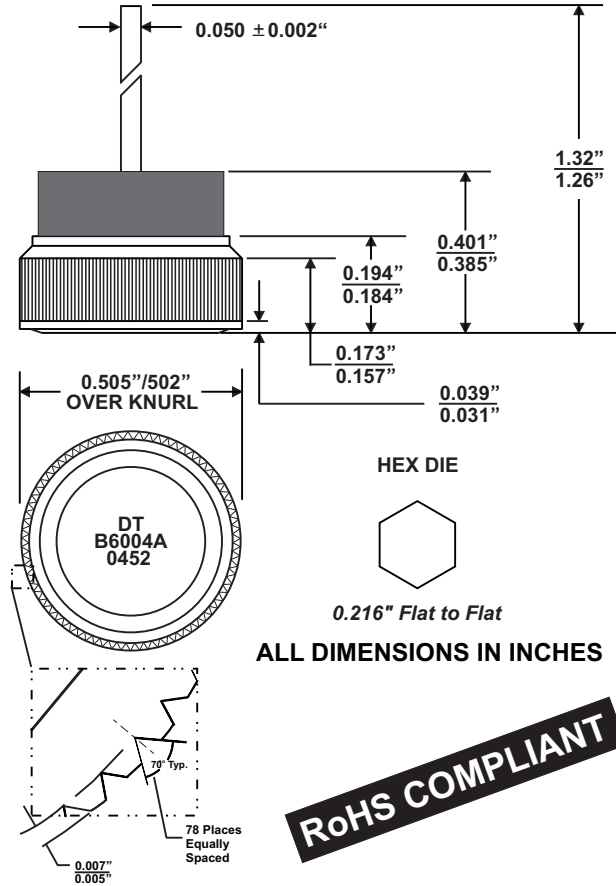

ALL DIMENSIONS IN INCHES

RoHS COMPLIANT

MAXIMUM RATINGS & ELECTRICAL CHARACTERISTICS

Ratings at 25°C ambient temperature unless otherwise specified.

PARAMETER (TEST CONDITIONS)	SYMBOL	RATINGS		UNITS
		B6002PFA B6002PFC	B6004PFA B6004PFC	
Series Number				
Maximum Recurrent Peak Reverse Voltage	VRRM	200	400	VOLTS
Working Peak Reverse Voltage	VRWM			
Maximum DC Blocking Voltage	VDC			
Non-Repetitive Peak Reverse Voltage (Half Wave, 60 Hz, Single Phase)	VRSM	240	480	
Average Forward Rectified Current	I _o	60	60	AMPS
Non-repetitive Peak Forward Surge Current (Half wave, single phase, 60 Hz sine applied to rated load)	I _{FSM}	720	720	
Forward Voltage Drop @ 60Amp DC (Typical)	V _F	<1.05	<1.05	VOLTS
Maximum DC Reverse Current at Rated Blocking Voltage T _c = 25°C	I _R	<2.0	<2.0	μA
Junction Operating & Storage Temperature Range	T _J , T _{STG}	-65 to +215	-65 to +215	$^{\circ}\text{C}$