

DIOTEC ELECTRONICS CORP
 18020 Hobart Blvd., Unit B
 Gardena, CA 90248 U.S.A
 Tel.: (310) 767-1052 Fax: (310) 767-7958

Looking For MR2500, MR2501,
 MR2502, MR2504, MR2506,
 MR2508, MR2510 Alternatives?

25 AMP BUTTON DIODES

FEATURES

- Suggested Alternative For The MR2500, MR2501, MR2502, MR2504, MR2506, MR2508, & MR2510
- Void Free Vacuum Die Soldering For Maximum Mechanical Strength And Heat Dissipation (Solder Voids: Typical $\leq 2\%$, Max. $\leq 10\%$ of Die Area)
- Large Die For High Power Heavy Duty Performance
- High Heat Handling Capability With Very Low Thermal Stress
- Proprietary Junction Passivation For Superior Reliability And Performance
- Low Forward Voltage Drop

MECHANICAL SPECIFICATION

Die Size:
 0.160" x 0.160"
 Square

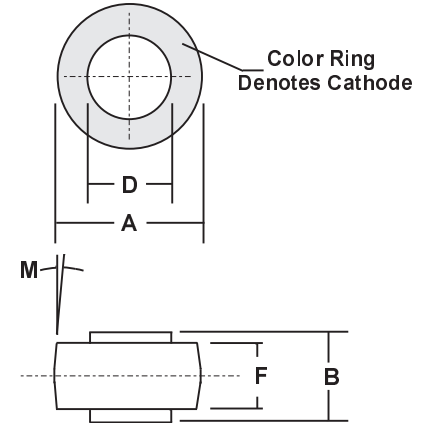

MECHANICAL DATA

- Case: Molded Epoxy (UL Flammability Rating 94V-0)
- Finish: All external surfaces are corrosion resistant and the contact areas are readily solderable
- Soldering Temperature: 265 °C maximum
- Mounting Position: Any
- Polarity: Color band denotes cathode
- Weight: 0.6 Ounces (1.8 Grams)

DIM	MILLIMETERS		INCHES	
	MIN	MAX	MIN	MAX
A	9.78	10.29	0.385	0.405
B	5.97	6.35	0.235	0.250
D	5.46	5.71	0.215	0.225
F	4.19	4.45	0.165	0.175
M	5° NOM		5° NOM	

RoHS COMPLIANT

MAXIMUM RATINGS & ELECTRICAL CHARACTERISTICS

Ratings at 25 °C ambient temperature unless otherwise specified.

PARAMETER (TEST CONDITIONS)	SYMBOL	RATINGS							UNITS
		DR 2500	DR 2501	DR 2502	DR 2504	DR 2506	DR 2508	DR 2510	
Series Number									
Maximum DC Blocking Voltage	VRRM								VOLTS
Maximum RMS Voltage	VRWM	50	100	200	400	600	800	1000	
Maximum Peak Recurrent Reverse Voltage	VDC								
Non-repetitive Peak Reverse Voltage (Half wave, single phase, 60 Hz peak)	VRSM	60	120	240	480	720	960	1200	
Average Forward Rectified Current @ Tc = 150 °C	IO	25							AMPS
Peak Forward Surge Current (8.3ms single half sine wave superimposed on rated load)	IFSM	400							
Maximum Forward Voltage Drop at 25 Amp DC	VFM	1.05 (Typical 1.00)							VOLTS
Maximum Average DC Reverse Current @ TA = 25 °C	IRM	1							µA
At Rated DC Blocking Voltage @ TA = 100 °C		50							
Maximum Thermal Resistance, Junction to Case (Note 1)	RθJC	0.95							°C/W
Junction Operating and Storage Temperature Range	TJ, TSTG	-65 to +175							°C

Notes: 1) Single Side Cooled