



4 AMP ULTRAFAST RECOVERY DIODES

FEATURES

- PROPRIETARY **SOFT GLASS[®]** JUNCTION PASSIVATION FOR SUPERIOR RELIABILITY AND PERFORMANCE
- VOID FREE VACUUM DIE SOLDERING FOR MAXIMUM MECHANICAL STRENGTH AND HEAT DISSIPATION (Solder Voids: Typical $\leq 2\%$, Max. $\leq 10\%$ of Die Area)
- LOW SWITCHING NOISE
- LOW THERMAL RESISTANCE
- HIGH SWITCHING CAPABILITY
- LOW FORWARD VOLTAGE DROP

MECHANICAL DATA

- Case: JEDEC DO-27 molded epoxy (U/L Flammability Rating 94V-0)
- Terminals: Plated axial leads
- Solderability: Per MIL-STD 202 Method 208 guaranteed
- Polarity: Color band denotes cathode
- Mounting Position: Any
- Weight: 0.04 Ounces (1.12 Grams)

RoHS COMPLIANT

MECHANICAL SPECIFICATION

ACTUAL SIZE OF DO-27 PACKAGE

SERIES UFR400 - UFR410

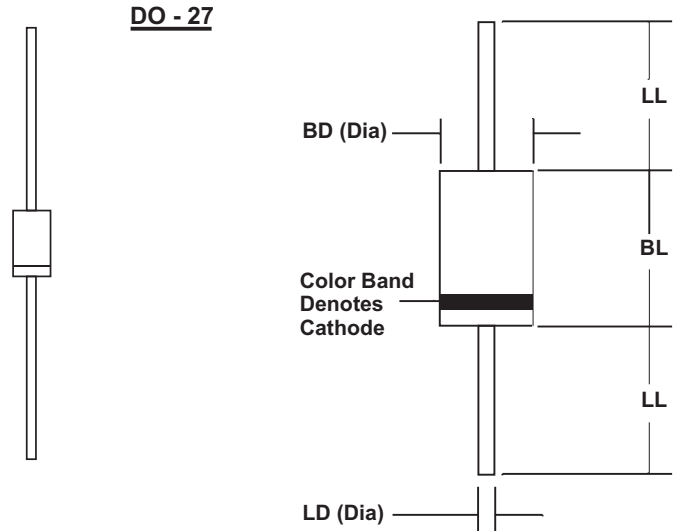

Sym	Minimum		Maximum	
	In	mm	In	mm
BL			0.365	9.28
BD			0.205	5.2
LL	1.00	25.4		
LD	0.048	1.2	0.052	1.3

MAXIMUM RATINGS & ELECTRICAL CHARACTERISTICS

Ratings at 25 °C ambient temperature unless otherwise specified.
 Single phase, half wave, 60Hz, resistive or inductive load.
 For capacitive loads, derate current by 20%.

PARAMETER (TEST CONDITIONS)	SYMBOL	RATINGS										UNITS
		UFR 400	UFR 401	UFR 402	UFR 403	UFR 404	UFR 406	UFR 408	UFR 409	UFR 410		
Series Number												
Maximum DC Blocking Voltage	V _{RM}	50	100	200	300	400	600	800	900	1000	VOLTS	
Maximum RMS Voltage	V _{RMS}	35	70	140	210	280	420	560	630	700		
Maximum Peak Recurrent Reverse Voltage	V _{RRM}	50	100	200	300	400	600	800	900	1000		
Average Forward Rectified Current @ T _A = (as shown)	I _O	@T _A =80°C					@T _A =55°C					AMPS
Peak Forward Surge Current (8.3mS single half sine wave superimposed on rated load)	I _{FSM}	200										
Maximum Forward Voltage at:	V _{FM}	3-Amps DC 4-Amps DC					1.20 1.25					VOLTS
Maximum Average DC Reverse Current At Rated DC Blocking Voltage	I _{RM}	@ T _J = 25 °C @ T _J = 125 °C					5 50					
Typical Thermal Resistance:	R _{θJL} R _{θJA}	Junction to Lead Junction to Air					7.5 18.0					°C/W
Typical Junction Capacitance (Note 1)	C _J	45										
Maximum Reverse Recovery Time (I _F =0.5A, I _R =1A, I _{RR} =0.25A)	T _{RR}	50			60			75				nSec
Junction Operating and Storage Temperature Range	T _J , T _{STG}	-65 to +175										°C

NOTES: (1) Measured at 1MHz and an applied reverse voltage of 4 volts.

3.01 of 403

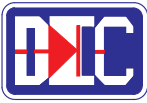

4 AMP ULTRAFAST RECOVERY DIODES

RATING & CHARACTERISTIC CURVES FOR SERIES UFR400 - UFR410

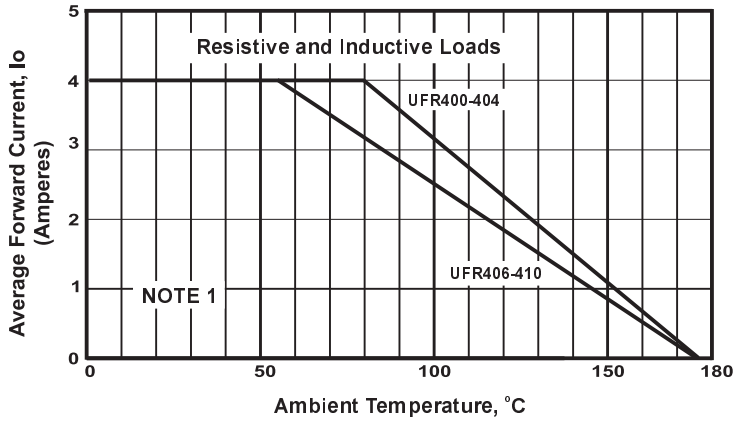

FIGURE 1. FORWARD CURRENT DERATING CURVE

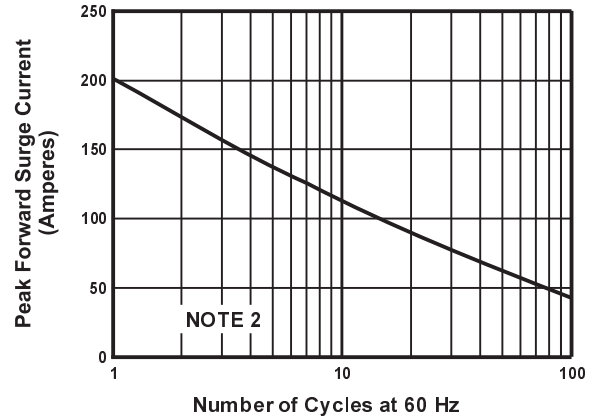

FIGURE 2. MAXIMUM NON-REPETITIVE SURGE CURRENT

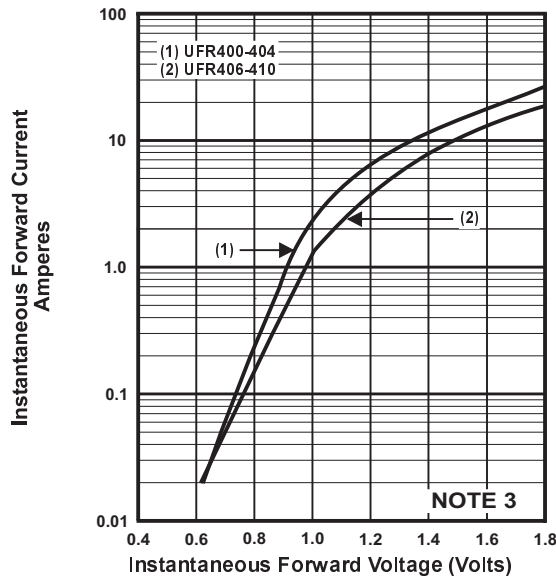

FIGURE 3. TYPICAL FORWARD CHARACTERISTICS

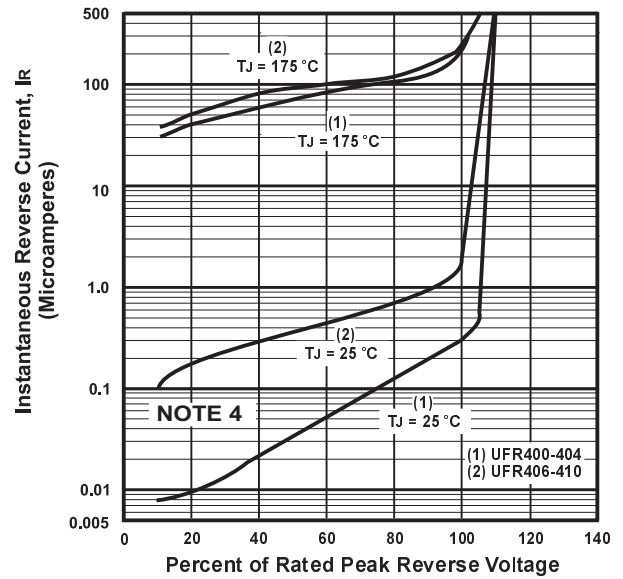

FIGURE 4. TYPICAL REVERSE CHARACTERISTICS

NOTES

- (1) Lead Length = 0.375" (9.5mm)
- (2) JEDEC Method, 8.3 mSec. Single Half Sine Wave
- (3) $T_J = 25^\circ\text{C}$, Pulse Width = 300 μSec , 2.0% Duty Cycle
- (4) These Curves Are Typical For The Highest Voltage Diode in The Voltage Grouping.

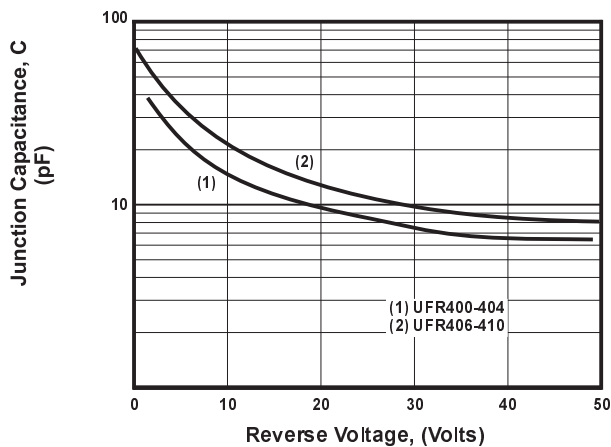

FIGURE 5. TYPICAL JUNCTION CAPACITANCE